

## STANDARD

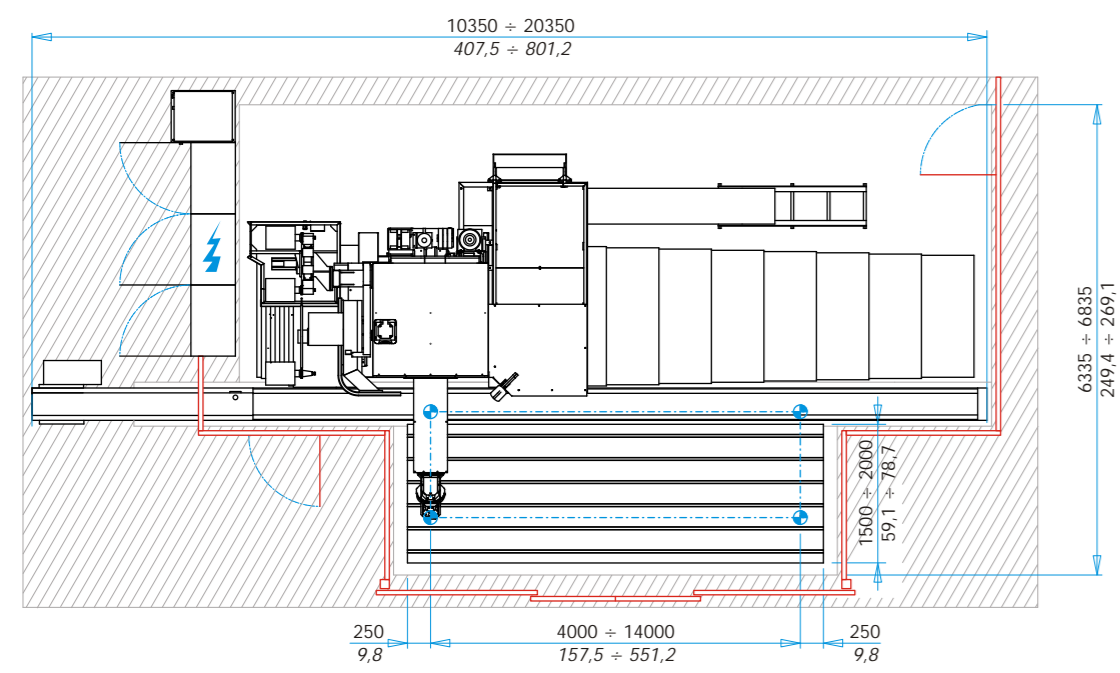
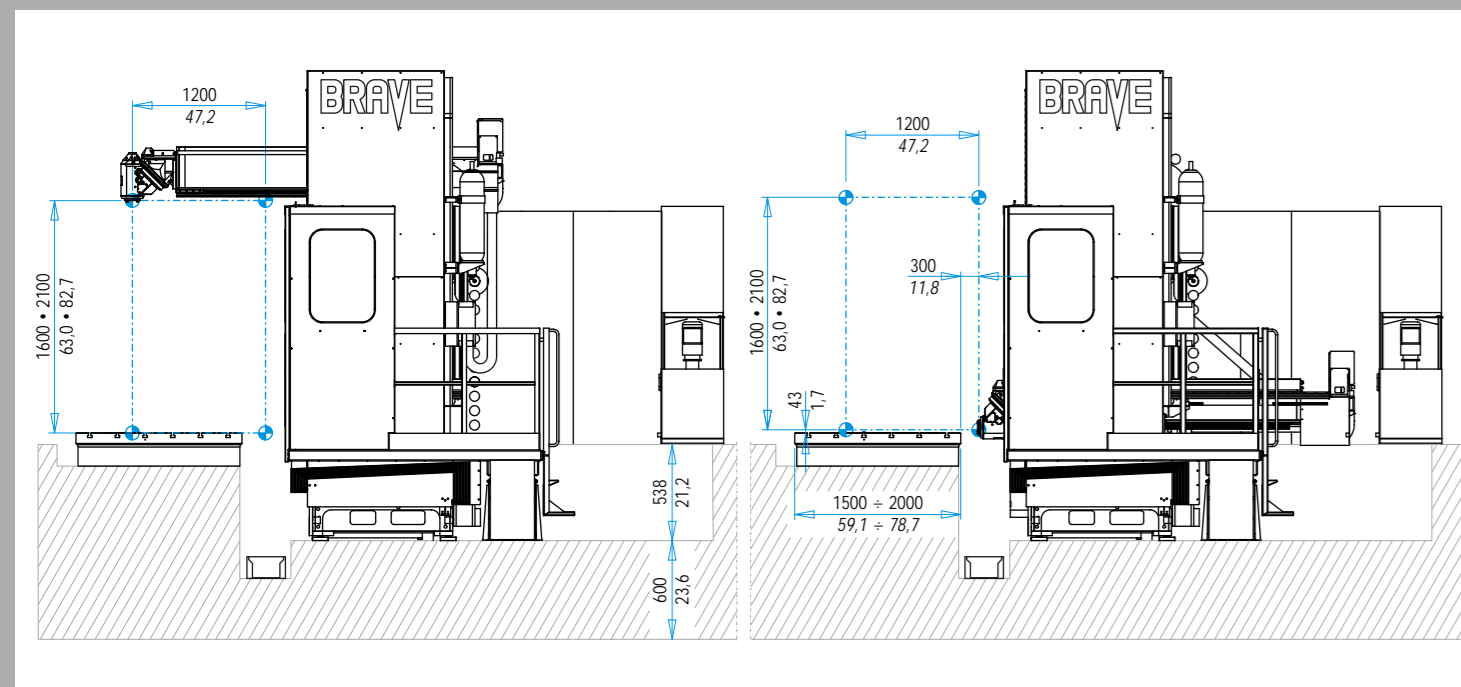
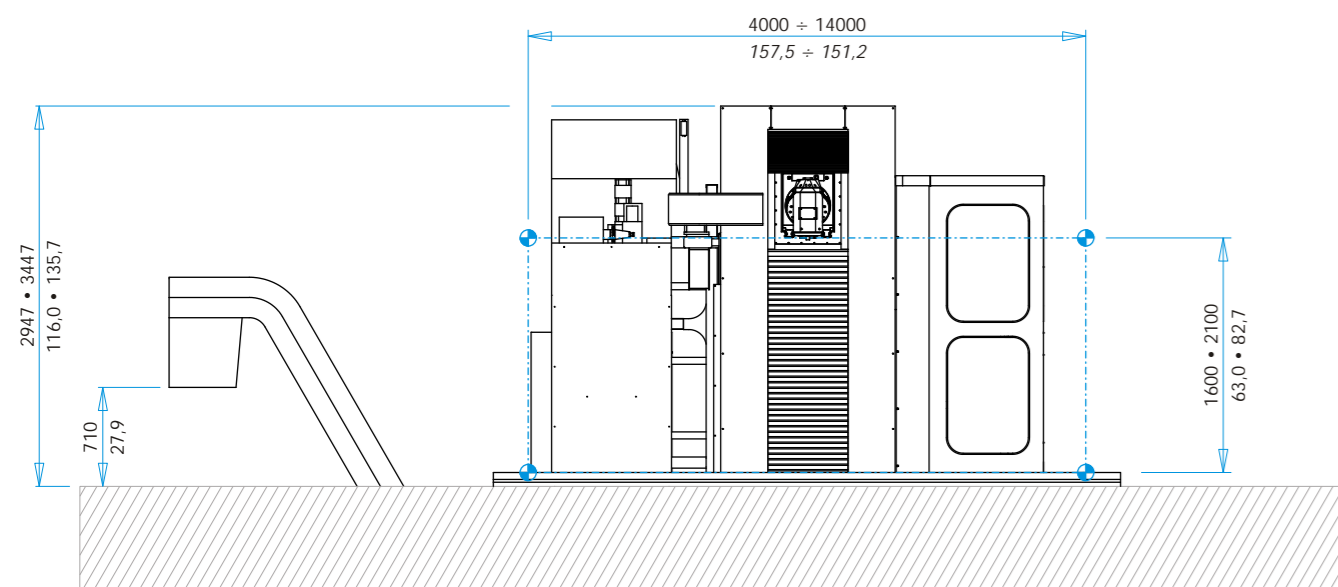

## BRAVE

CORSE TRAVELS VERFAHRWEGE COURSES			
Longitudinale • Longitudinal Längs • Longitudinale	mm inch	4000 ÷ 14000 (passo 2000) 157,5 ÷ 551,2 (step 78,7)	
Trasversale • Cross Quer • Transversal	mm inch	1200 47,2	
Verticale • Vertical Senkrecht • Verticale	mm inch	1600 • 2100 63,0 • 82,7	

AVANZAMENTI FEEDS VORSCHÜBE AVANCES			
Rapidi • Rapids Eilgang • Rapides	mm / 1' ipm	0 ÷ 30000 0 ÷ 1181,1	
Di lavoro • Work Arbeitsgang • De Travail	mm / 1' ipm	0 ÷ 15000 0 ÷ 590,6	
Accelerazioni max • Max Accelerations Max Beschleunigung • Acceleration Maxi	mm/sec <sup>2</sup> ipm/sec <sup>2</sup>	3000 118,1	

MANDRINO SPINDLE SPINDEL BROCHE			
Potenza costante • Rated output Konstante Leistung • Puissance constante	KW	30	
Coppia costante • Rated torque Konstanten Drehmoment • Couple constante	Nm	400	
Velocità mandrino • Spindle speed Spindeldrehzahl • Vitesse broche	g/1' rpm	4000 (5000 - 6000 - 8000)	
Cono mandrino • Spindle taper Spindelaufnahme • Cone broche	ISO 50 HSK 100A	DIN 69871 A DIN 69893	

TAVOLA TABLE TISCH TABLE			
Larghezza tavola • Width of table Breite Tisch • Largeur de la table	STANDARD	mm inch	1500 • 2000 59 • 79
	UNIBLOCK	mm inch	1500 59,0
Cave a "T" • "T" slots "T" Nuten • Rainures en "T"	STANDARD	mm inch	28 1,1
	UNIBLOCK	mm inch	28 1,1
Peso max ammesso • Admitted weight Max Tischlast • Poids admis	STANDARD	Kg/m <sup>2</sup> Lb / m <sup>2</sup>	15000 33070
	UNIBLOCK	Kg/m <sup>2</sup> Lb / m <sup>2</sup>	10000 22050

CAMBIO UTENSILI TOOL CHANGER WERKZEUGWECHSEL CHANGEUR D'OUTILS			
Automatico - capacità Automatic - capacity Automatisch - Ladekapazität Automatique - capacité	Utensili Tools Werkzg Outils	24 ÷ 80	



PARPAS AMERICA INC.  
430 Pelissier Street - Suite 405  
Windsor, ONT. N9A 4K9 CANADA  
Tel. +1-800-831-9092 • Fax +1-734-462-9244  
sales@parpasamerica.com

O.M.V. Officine Meccaniche Venete S.r.l.  
Via Caltana 167  
30030 Caltana di Santa Maria di Sala (VE)  
Tel. 0415709900 • Fax 0415730776  
info@omvsrl.it

PARPAS AMERICA CORP.  
36030 Industrial Road  
Livonia, MI 48150 USA  
Tel. +1-734-462-0204 • Fax +1-734-462-9244  
sales@parpasamerica.com



BRAVE



## UNIBLOCK

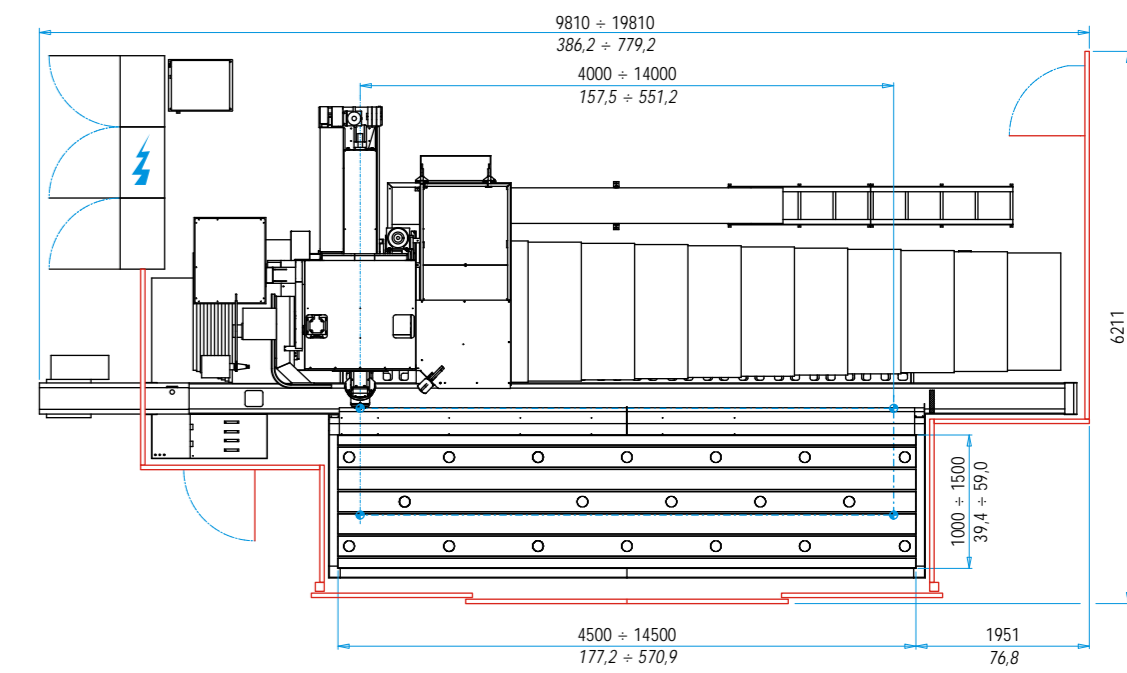
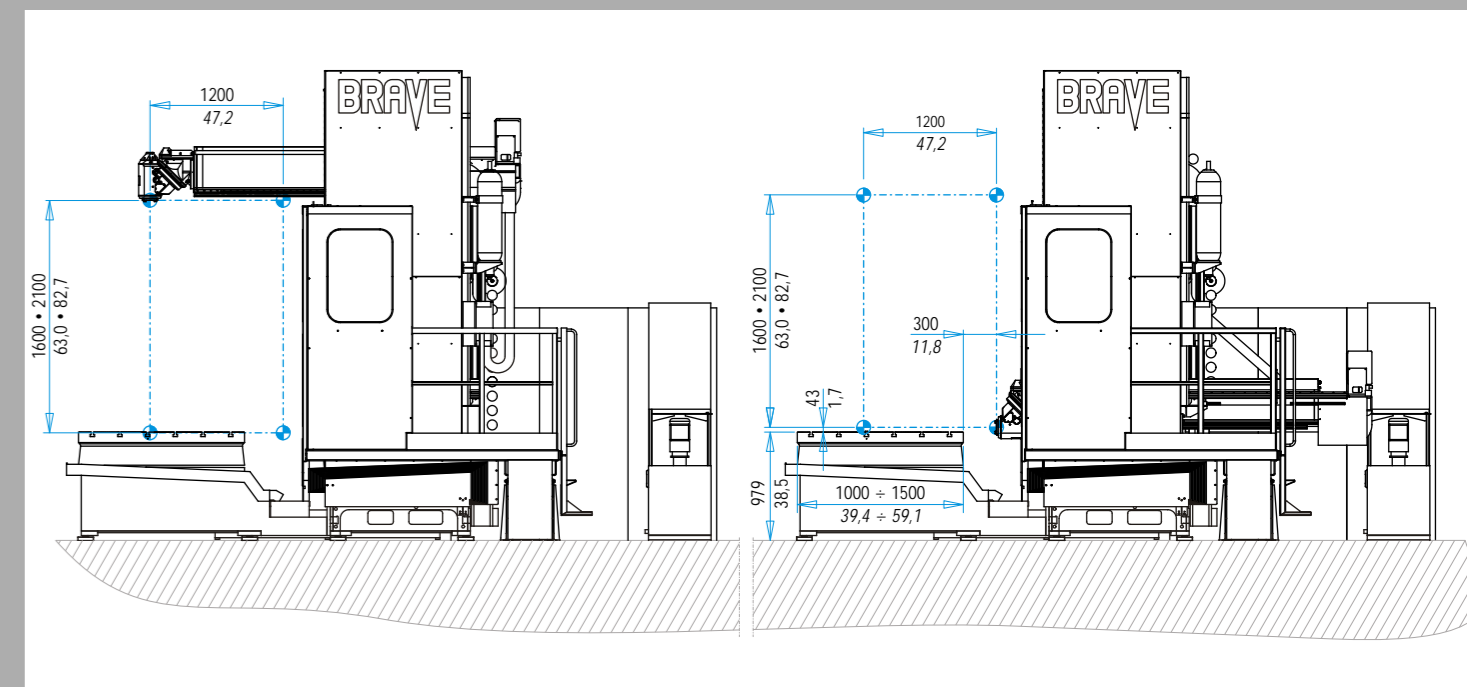
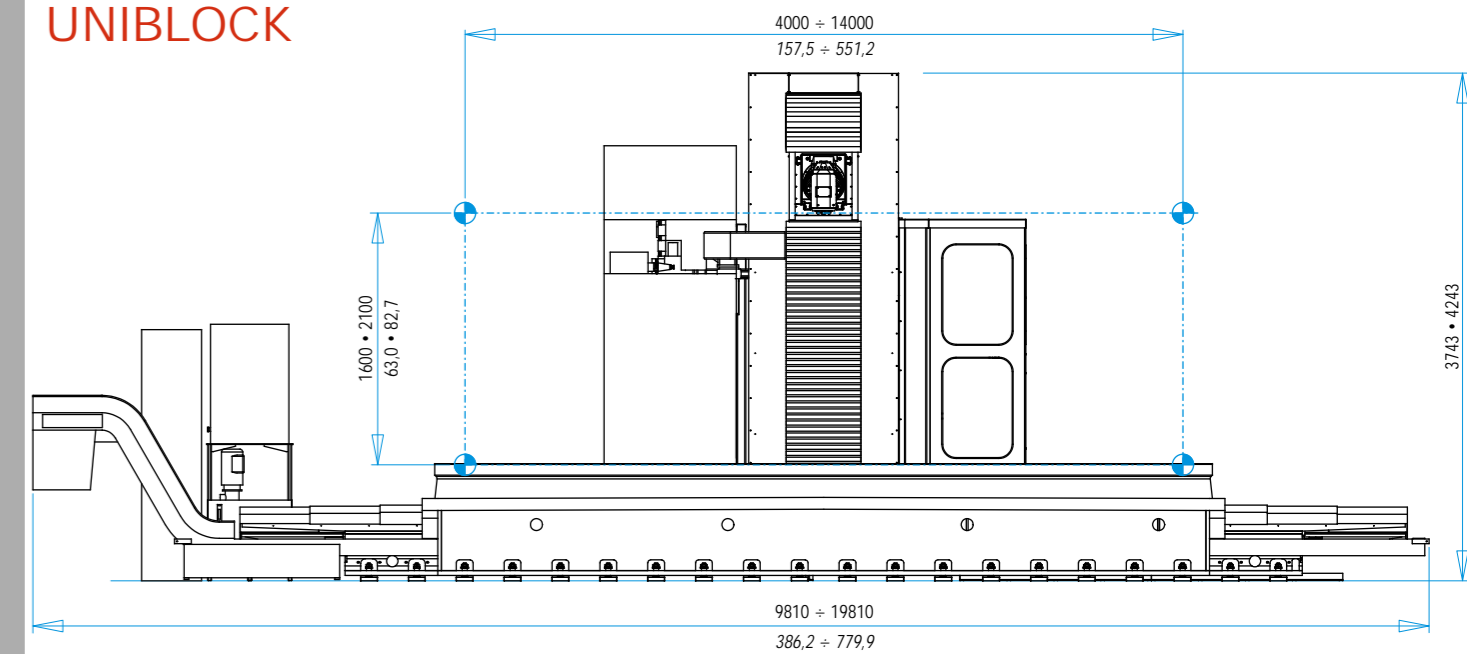



Testa universale indexata o a posizionamento continuo.  
*Universal indexed milling head or with continuous positioning.*  
*Zwei Achsen indexierter Universal-Fräskopf oder, stufenlos schwenkbar.*  
*Tête universelle indexée ou à positionnement en continu.*

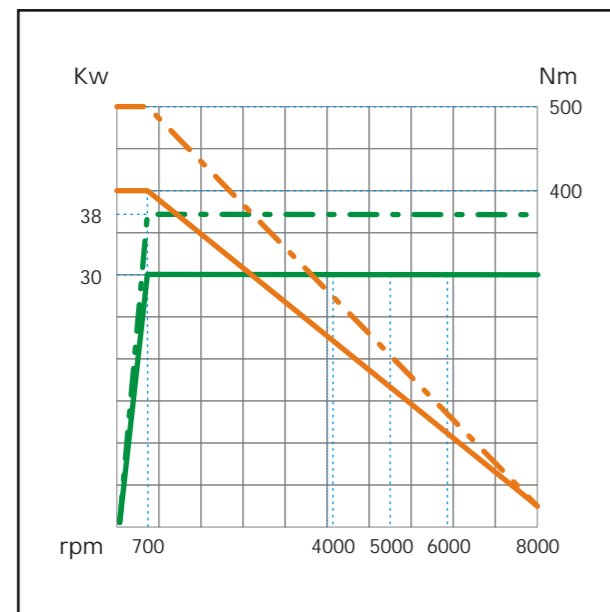

MOTORE AC SINCRONO • SYNCHRONOUS-MOTOR  
 SYNCHRON-MOTOR • MOTEUR SYNCHRONE

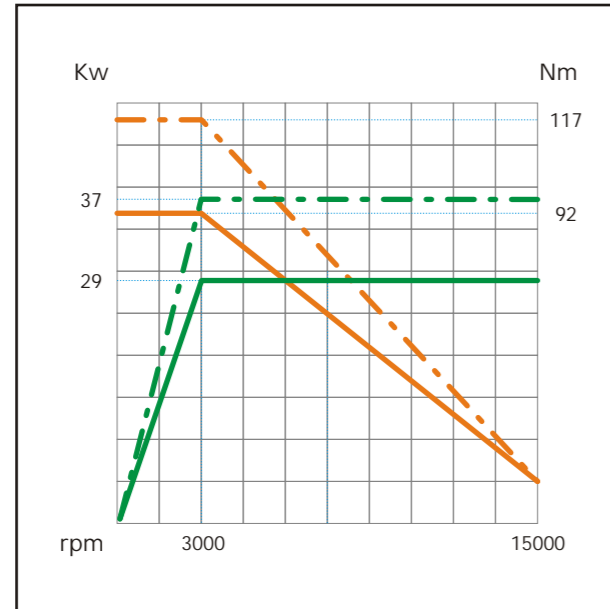

Testa universale con motorspindle  
*Universal milling head with motorspindle*  
*Zwei Achsen Universal-Fräskopf mit Motorspindel*  
*Tête universelle avec moteur-broche*



Prolunga orizzontale  
*Horizontal head extension*  
*Spindelverlängerung*  
*Prolongement horizontal*

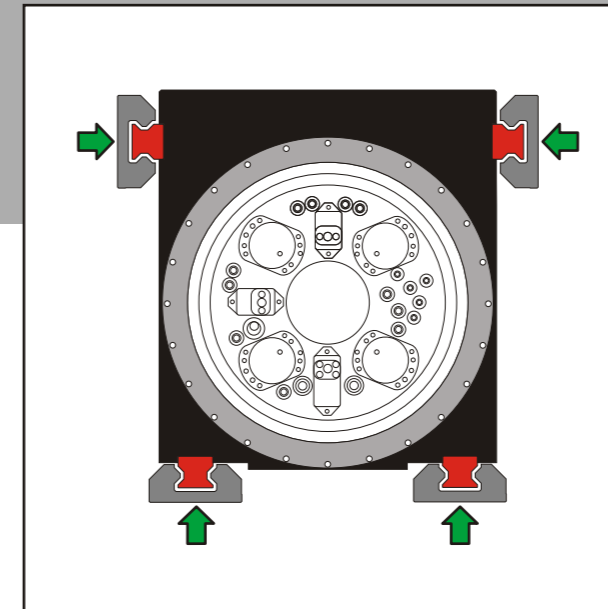

Asse trasversale - 8 pattini su 4 guide  
*Cross axis - 8 runners on 4 guideways*  
*Quer Achse - 8 Rollschuhe auf 4 Führungen*  
*Axe transversal - 8 patins sur 4 glissières*



Cabina operatore  
*Operator's box*  
*Kabine Fachmann*  
*Cabine opérateur*



Montante, basamento e carro  
*Column, bed and carriage*  
*Ständer, Bett und Karre*  
*Montant, bâti et char*

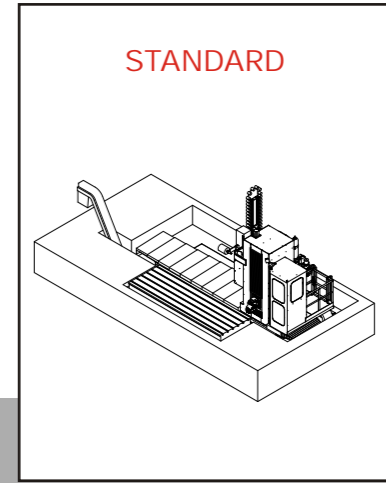

STANDARD

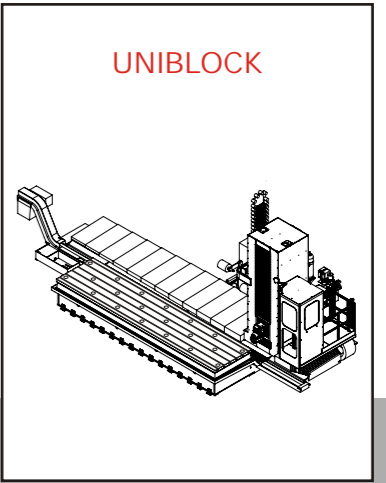

UNIBLOCK



Cambio teste opzionale  
*Optional heads change*  
*Fräskopf-wechsel optionelle*  
*Changer de têtes optionell*



Cambio utensili a catena fino a 80 posti  
*Chain tool changer up to 80 places*  
*Werkzeug-magazin bis zu 80 Plätzen*  
*Changeur d'outils à chaîne jusqu'à les 80 places*



Tavole girevoli e rototraslanti  
*Rotary and sliding tables*  
*CN-Drehtischen ist vorhanden und dabei*  
*Plateaux rotatifs et déplaçables*

Le caratteristiche non sono impegnative e ci riserviamo il diritto di modificarle in qualsiasi momento.  
 The above specifications are not binding and we reserve the right to modify them at anytime when deemed necessary.  
 Die angegebenen Kennzeichen sind unverbindlich. Das Recht auf Änderungen bleibt jederzeit vorbehalten.  
 Les données ne sont pas engageantes et nous réservons le droit de les modifier à n'importe quel moment.